

Scroll Wheel Module – Panel Mount, Hall Effect Technology, IP68



1. DESCRIPTION

The SWM Scroll Wheel Module is a high specification human interface device that provides the same scroll, pan, and middle switch functionality found in scroll wheels installed in commercial desktop mice.

Utilizing reliable non-contacting Hall effect technology, the SWM scroll wheel provides environmental protection up to IP68 (IEC 60529) ensuring continued operation even when exposed to the most extreme environments.

The scroll wheel module provides various configuration options including; optional wheel colours, optional backlight LED lighting for use in low level environments, optional detent-scrolling mechanism, and a choice of rear or front panel mounting.

The module is available with a variety of electrical outputs and has been designed for integration into OEM Keyboards and consoles.

2. FEATURES

- Hall effect encoding technology
- Sealing up to IP68 (IEC 60529)
- Integrated switch function (middle button function)
- Detent scrolling mechanism
- USB & PS2 (auto-select) or TTL quadrature output
- Smooth operation in rugged environments
- Various wheel colours available
- Backlight LED illumination feature available
- Custom mounting bracket options available (please contact a local sales representative for further details)

3. APPLICATIONS

- Industrial control panels
- Military/Marine/Medical user interface panels
- Sound and lighting consoles
- Colour correction consoles
- OEM custom solutions available

4. SCROLL WHEEL MODULE CONFIGURATIONS

4.1 INSTALLATION OPTIONS

The scroll wheel module can be installed into the front face of a panel or from the rear of the panel. Please refer to the part ordering code section for configuration options (see section 8).

4.1.1 REAR PANEL INSTALLATION

The scroll wheel module, when configured to be installed to the rear of a panel, utilises a standard mounting bracket with integrated sealing gasket.

A typical installation arrangement should include;

- 1 x 3mm thick metal panel (recommended).
- 4 x M3 threaded studs (M3 x 20mm) spot welded/pressed to the underside of the metal panel.
- 4 x M3 nuts and lock washers (not supplied).

NOTES:

Please note that fixings and fasteners are not included with the scroll wheel module.

Please refer to section 7 for recommended panel cut-out dimensions and M3 threaded stud locations.

Custom installation brackets are available on request - please contact your local sales office for more information.

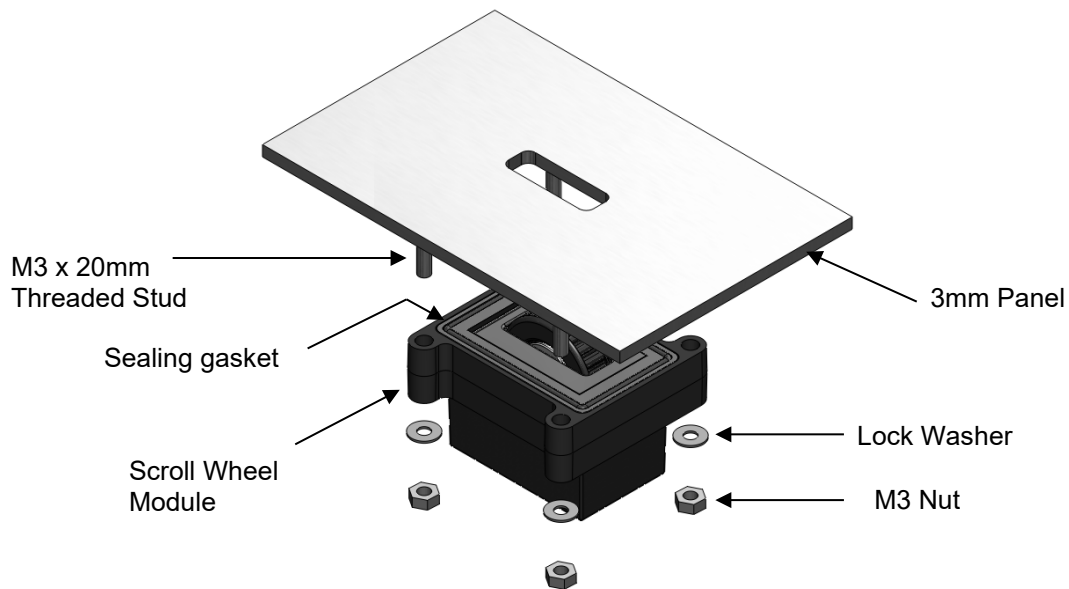

Figure.1 Exploded view of typical rear panel installation

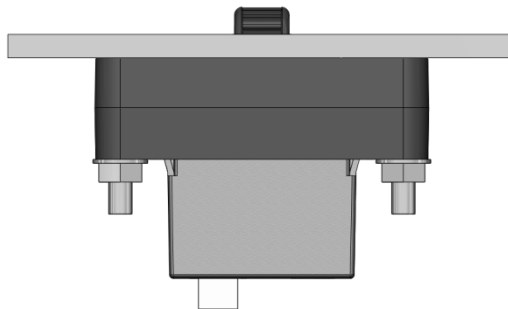

Figure.2 Front view of scroll wheel module installed into the rear of a panel

4.1.2 FRONT PANEL INSTALLATION

The scroll wheel module, when configured to be installed into the front face of a panel, utilises 4 x snap features integrated into the plastic housing. A sealing gasket is incorporated into the module to provide protection from ingress of water and dust.

The module has been designed to be mounted into panels with a thickness of between 1mm and 3mm.

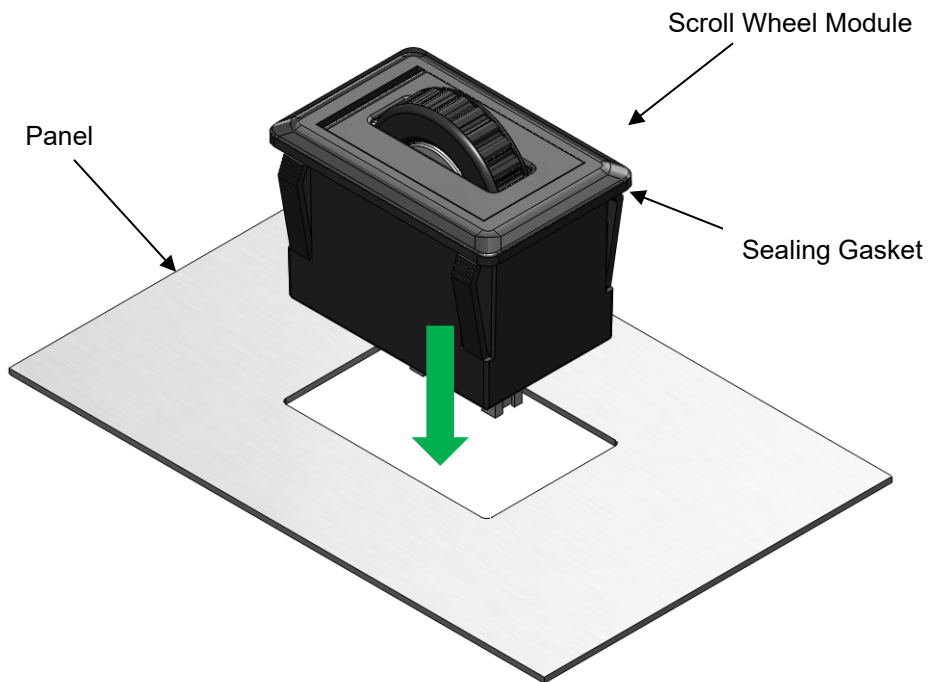

Figure.3 Exploded view of a typical front panel installation

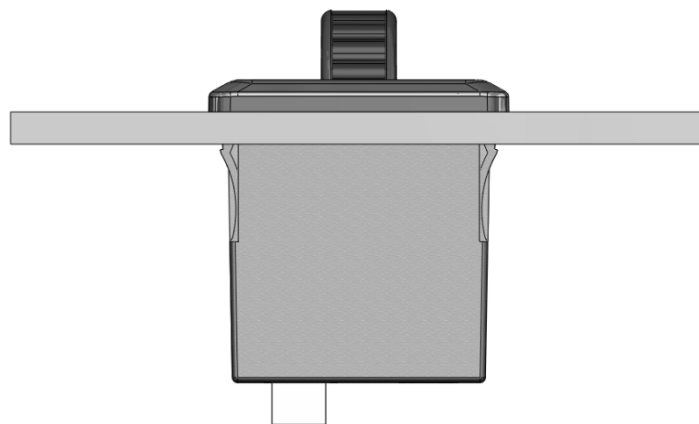

Figure.4 Front view of scroll wheel module installed into the front of a panel

4.2 DETENT SCROLLING MECHANISM

The scroll wheel module includes a detent scrolling mechanism that provides an audible click and tactile feedback for each output on the screen/system.

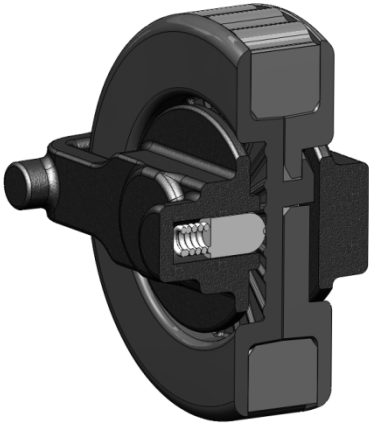

Figure.5 Detent mechanism cross-section

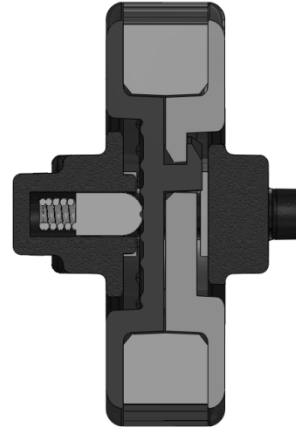

Figure.6 Detent mechanism cross section – front view

4.3 SCROLL WHEEL COLOUR

The scroll wheel module is configured to include a grey wheel as standard - please contact your local sales representative for details regarding specific wheel colour requirements.



Customisation of the wheel shape and colour is also possible – please contact your local sales representative for further information.



4.4 LED ILLUMINATION FEATURE

The scroll wheel module can be configured to provide a white LED illumination of the outer edges of the wheel. The illuminated edges provide an excellent means of locating the scroll wheel in low level light environments and also serve as an aesthetic feature to compliment other illuminated components that may be incorporated within a user interface panel (e.g. illuminated switches).

Figures 6 and 7 below show the LED illumination feature in its powered and non-powered state.



Figure.6 Scroll wheel – non-illuminated

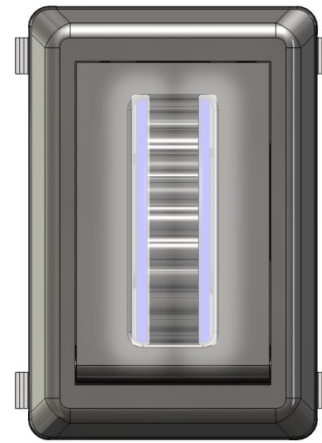
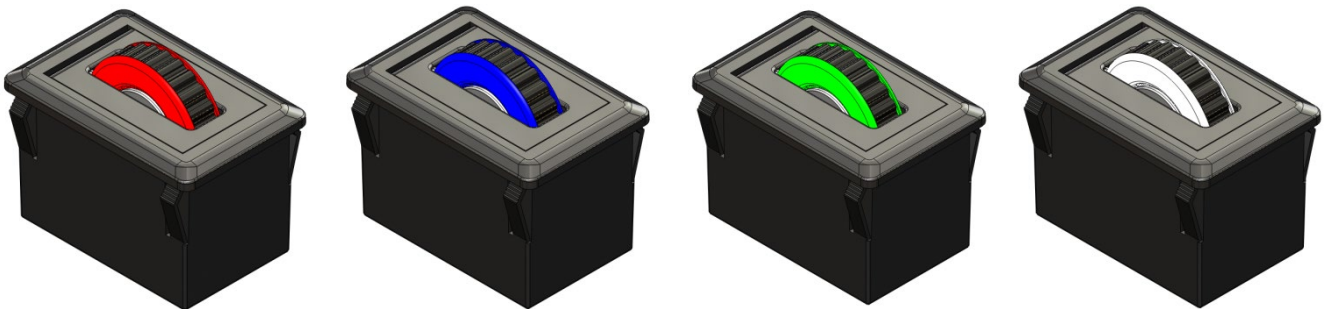

Figure.7 Scroll wheel – illuminated

Customisation of the illumination colour is also possible – please contact your local sales representative for further information.



5. SPECIFICATIONS

5.1 MECHANICAL		
5.1.1	Weight	22 grams
5.1.2	Wheel diameter	Ø25mm
5.1.3	Wheel shaft diameter/material	Ø 3.0mm, Ni-Cu-Ni plated Magnetic Neodymium Iron Boron
5.1.4	Magnet strength	N42
5.1.5	Wheel material/colour	PC/ABS, Grey
5.1.6	Housing material/colour	PC/ABS, Black
5.1.7	Encoding technology	Hall effect technology
5.1.8	Detent scrolling force	30 grams nominal (optional – see section 8)

5.2 ELECTRICAL		
5.2.1	Protocol	USB & PS2 (auto-select) or TTL Quadrature
5.2.2	Supply voltage	4.4V to 5.25V D.C.
5.2.3	Supply current – non illuminated	25mA typical, 30mA maximum
5.2.4	Supply current – White LED illuminated	50mA typical, 65mA maximum
5.2.5	Resolution	24 counts per wheel revolution
5.2.6	Output connector	6 Way JST, vertical header, part no B6B-PH-SM4-TB
5.2.7	Mating output connector	6 Way JST connector, part no: PH, CR or KR types (e.g. PHR-6)
5.2.8	Integrated switches	1 x low profile tactile switch providing middle button functionality
5.2.9	Switch actuation force	150 ± 50grams force

5.3 ENVIRONMENTAL		
5.3.1	Operating temperature	0°C to +55°C (IEC 60068-2-1, IEC60068-2-2)
5.3.2	Storage temperature	-40°C to + 85 °C (IEC 60068-2-1, IEC60068-2-2)
5.3.3	Operating humidity	93% RH @ 40°C, non-condensing (IEC 60068-2-78)
5.3.4	Storage humidity	10%-95% non-condensing (IEC 60068-2-78)
5.3.5	Vibration	2g, 10-500Hz, 1 octave/min, 10 sweep cycles (IEC 60068-2-6)
5.3.6	Operating Shock	15g/11ms, ½ sine, 3 shocks in +ve and –ve direction, all 3 axes (IEC 60068-2-27)
5.3.7	Mechanical lifetime	1 million wheel revolutions
5.3.8	MTBF	in excess of 80,000 hours (MIL-STD-217F)
5.3.9	ESD	15kV air-discharge and 8kV contact discharge (IEC 61000-4-2)
5.3.10	EMC	Radiated immunity - limits according to level 3 of IEC 61000-4-3 Radiated emissions to EN55022 class B
5.3.11	Sealing capability	IP68 (BS EN 60529)

5.4 Electrical Compatibility

The scroll wheel module has been tested for compatibility with the following operating systems;

Windows 95
Windows 98
Windows 2000
Windows ME
Windows NT4
Windows XP
Windows Vista
Windows 7
Redhat Linux
Fully compliant with USB 1.1 framework (chapter 9) and HID specifications

6. CONNECTION DETAILS

Connection is made to the scroll wheel module by means of a 6 way JST connector. Table 1 highlights the connection details.

6.1 Output Connector: P1

Description: 6 way, 2.0mm pitch, vertical connector
Manufacturer: JST (or equivalent)
Part No: B6B-PH-SM4-TB

Pin Number	USB & PS/2	TTL Quadrature
1	Earth	Switch Return
2	Do Not Connect ^[1]	Switch (N.O.) ^[2]
3	+5V	+5V
4	D-, PS/2 Data	Z1
5	D+, PS/2 Clock	Z2
6	0V	0V

Table 1 Output connections

NOTE 1: Pin to be left floating (unconnected)

NOTE 2: Switch operation is normally open.

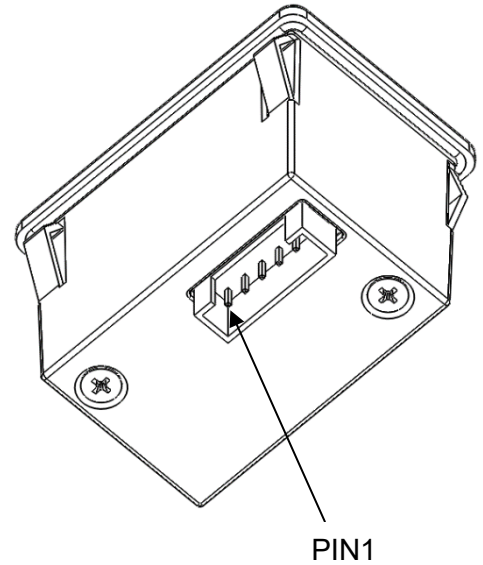

6.2 Internal Switch Schematic (TTL Quadrature Only)

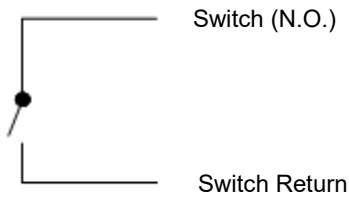

6.3 Internal Switch Specification

Mechanical lifetime	300,000 operations
Travel (mm)	0.25 + 0.2mm/- 0.1mm
Operating Force	150 ± 50 grams force

Table 2 Switch Specification

7. DIMENSION DRAWING - FRONT OF PANEL INSTALLATION

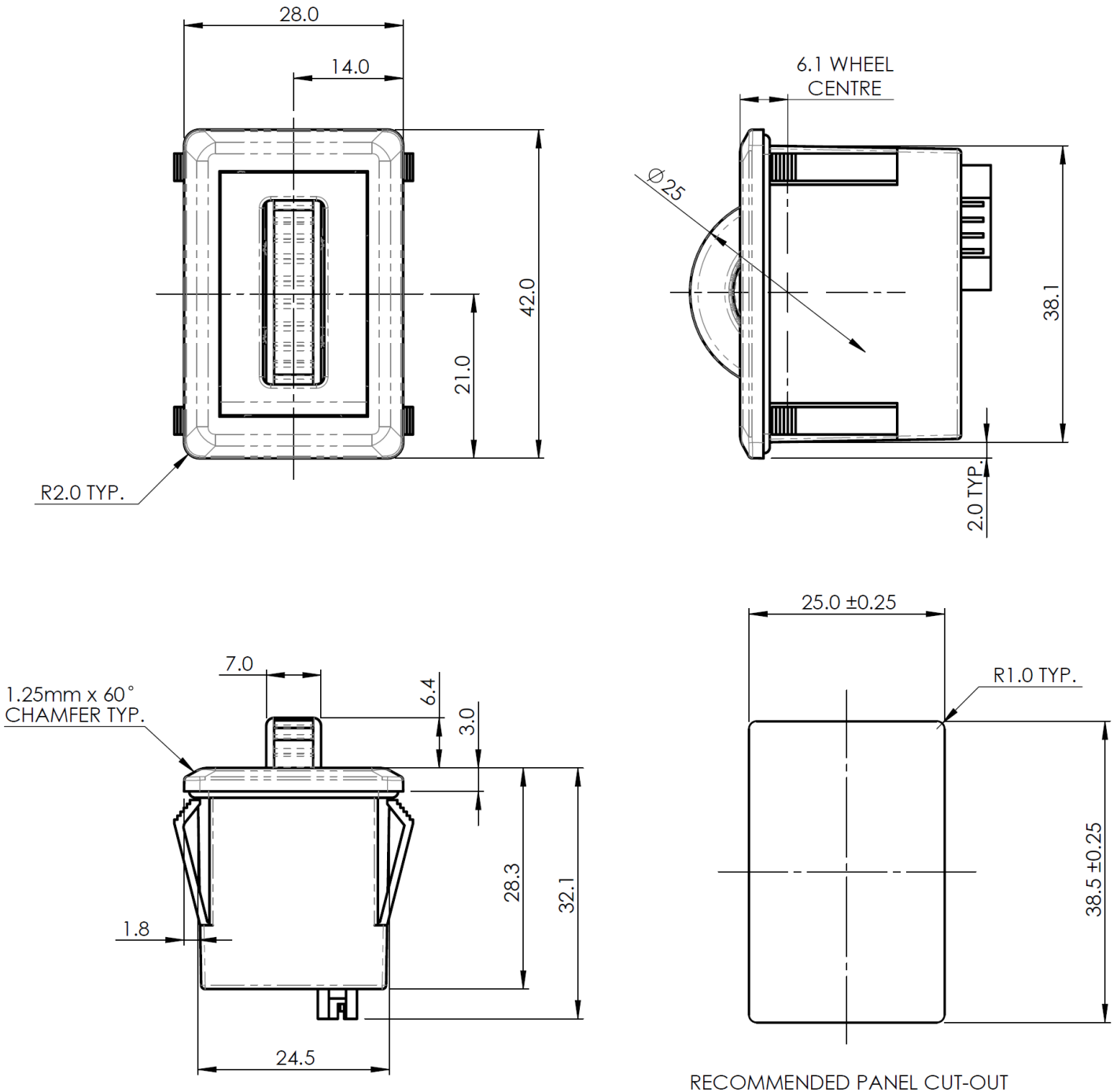

Dimensional drawing specifies factory default orientation.
All dimensions are in mm unless otherwise stated.
Tolerances +/- 0.2mm unless otherwise stated
Please note that an IGES model is available on request. Please contact your local sales office for more information.

7. DIMENSION DRAWING - REAR PANEL INSTALLATION

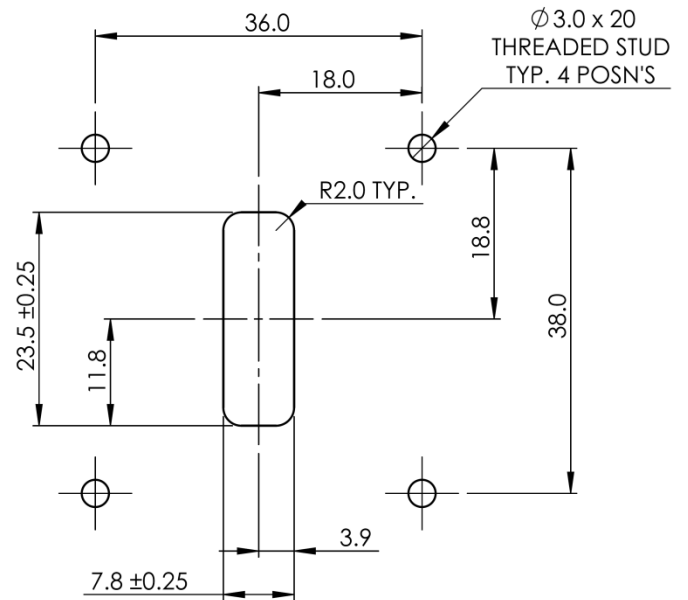
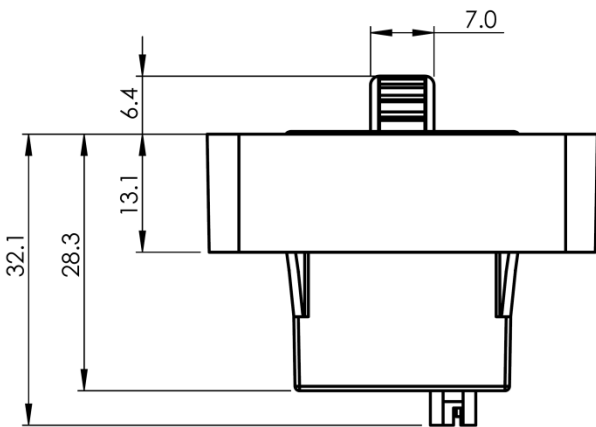
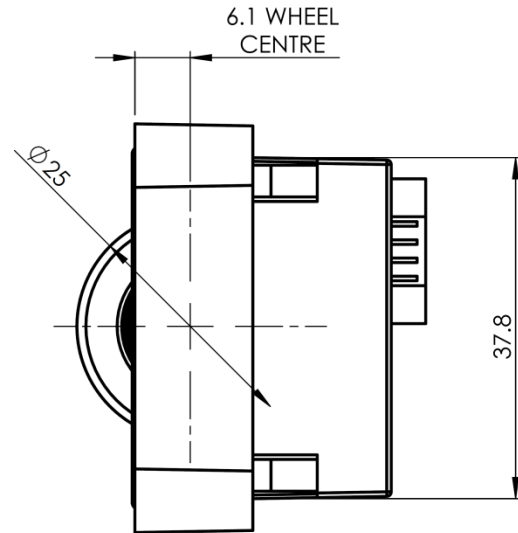
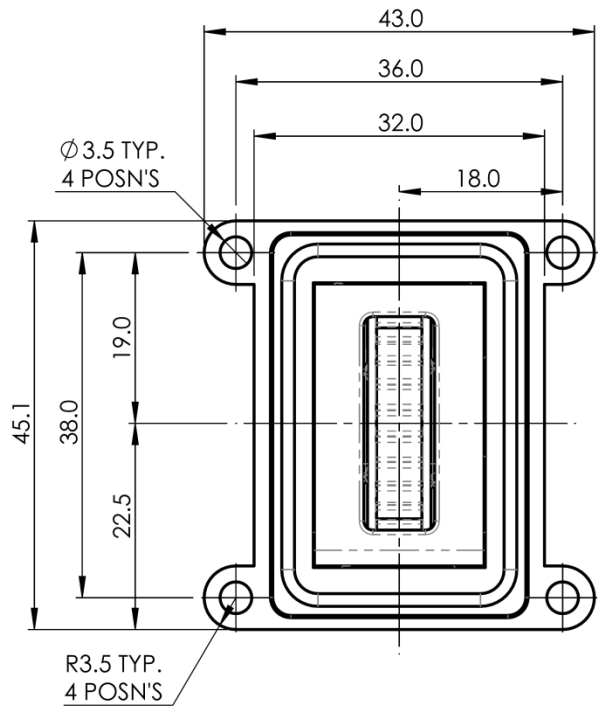

RECOMMENDED PANEL CUT-OUT

Dimensional drawing specifies factory default orientation.

All dimensions are in mm unless otherwise stated.

Tolerances +/- 0.2mm unless otherwise stated

Please note that an IGES model is available on request. Please contact your local sales office for more information

Custom mounting bracket options are available on request. Please contact your local sales office for more information.

8. PRODUCT ORDERING CODE SYSTEM

Please construct your standard product ordering code by selecting the numbers and letters to suit your specification:

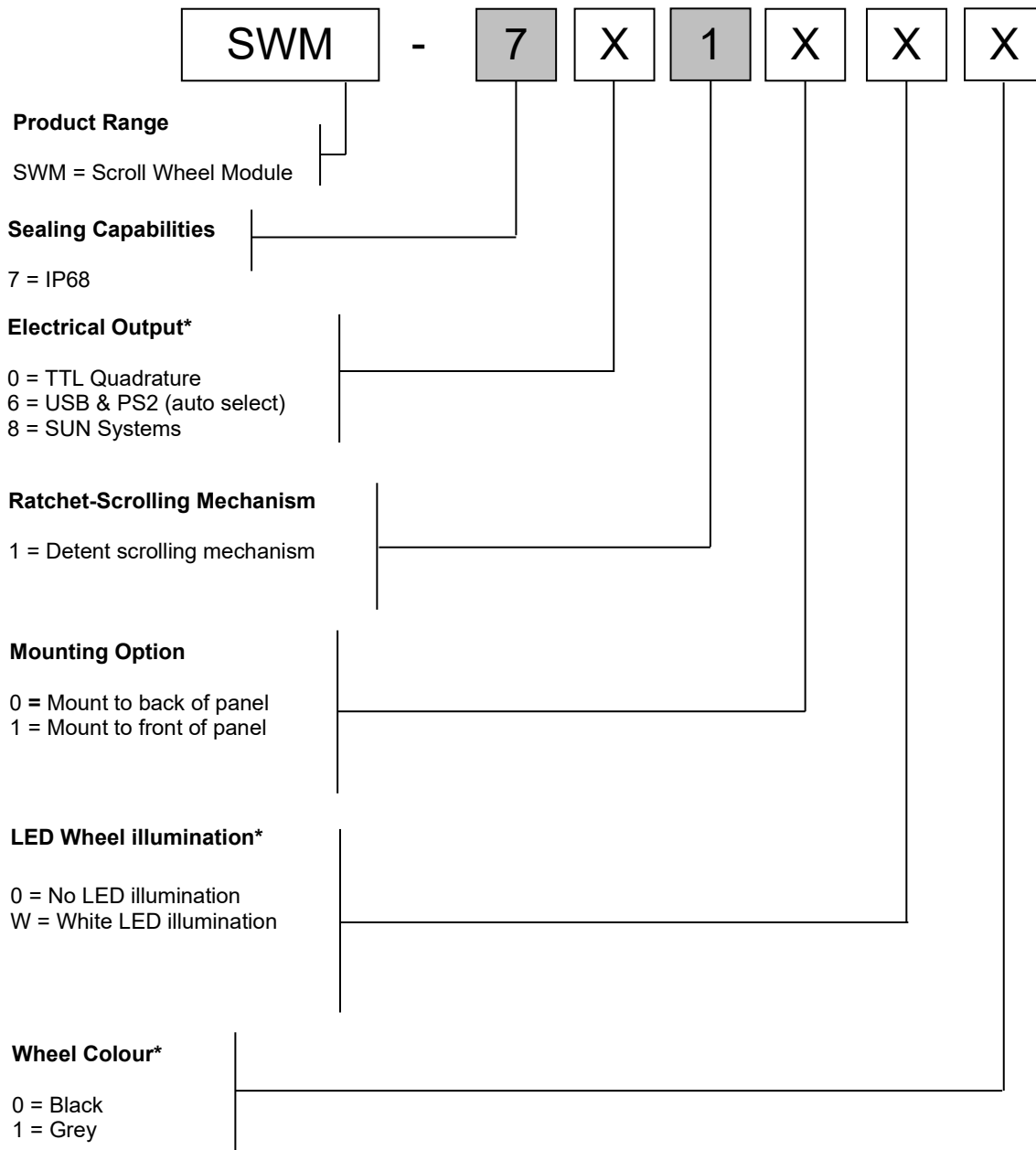

*For further options please contact your local sales representative for further details

8.1 Ordering Example

SWM-761001: Scroll Wheel module, IP68, USB & PS2, detent scrolling mechanism, mount to back of panel, no LED illumination, grey wheel.

SWM-7010W1: Scroll Wheel module, IP68, TTL Quadrature, detent scrolling mechanism, mount to back of panel, White LED illumination, grey wheel.